

A high-angle, low-look shot of a skyscraper under construction. The building's facade is covered in a grid of blue-tinted glass panels, reflecting the sky. The steel framework is visible, and the building rises steeply against a clear blue sky.

Earthing system

Tested to IEC 62561, UL 467

Maintenance free earthing system as per NBC-2016
Residential, Commercial & Industrial solutions



Earth Electrodes and Maintenance:

Corrosion of Earth Electrodes in soil often reduces the efficiency of earthing system, creating challenge to electrical and electronic engineers. Failures and accidents are often due to poor quality earthing installation. Use of GI/CI pipes along with salt and charcoal as specified in IS3043 provide quick results in earth resistance, but will corrode the electrode much faster.

Use of non standard earth electrodes together with chemical compound in the earth pit (often called as chemical earthing, pipe-in-pipe earthing, digital earthing etc) not only increased the problem of earthing, but created lot of imaginary requirements in earthing. As a result engineers often ask for an earth electrode resistance of 1 ohm, which is unfortunately impossible in most places.

Maintenance Free Earthing as per NBC-2016:

National Building Code of India (NBC-2016) provide updated and clear requirements of maintenance free earth electrodes and its installation. Primary requirement of earth electrode is its capability to withstand corrosion and adequate mechanical strength for the intended lifetime.

Maintenance free earth electrode is an installation where the electrodes are tested as per IEC62561-2, exothermically welded to copper flat including Earth enhancing material tested as per IEC 62561-7.

Maintenance free earthing Installation as per NBC-2016 need high quality earth electrodes with copper coated steel rods, exothermic welding and earth enhancement material. This installation primarily increase the life of installation and reduce electrochemical and galvanic corrosion.

Corrosion due to Bi-Metallic effects of earth electrodes are known for years where as information on Corrosion due to galvanic effects are relatively new. Use of copper coated rods over GI / CI is recommended in IS/IEC 62305 to overcome corrosion due to galvanic effect. Maintenance free earthing as per NBC-2016 will provide long life in almost every environment.

Resistance of earth electrode to soil depends mainly on the soil resistivity of the place where it is installed. Compounds used as earth enhancing materials can improve this value to some extend. For getting low resistance value the only way is to either increase the length of rod vertically or install more electrodes interconnected in parallel.

No electrical requirement need an earth electrode with a resistance near to 1 ohm. Minimum requirement of 10 ohms as per IS/IEC62305-3 can be disregarded with the recommended length of electrode confirming the above standards. Some standards recommend a value of near to 5 ohm predominantly to ensure the touch and step potential limits during an electrical fault.

**Maintenance free earthing as per NBC-2016
(copper / copper bonded rod with exothermic welding)**

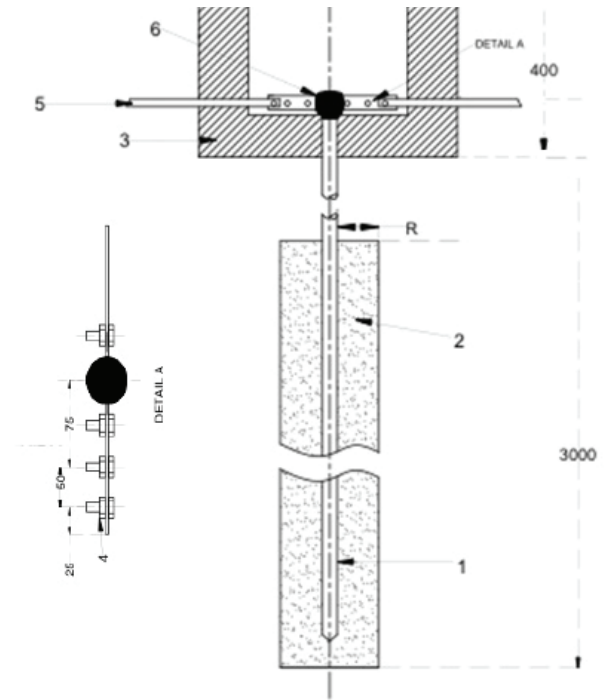

1. Copper / Copper bonded steel rod tested to IEC 62561
2. Earth Enhancement Material confirming to IEC 62561
3. Inspection Chamber
4. M10 Bolts and Nuts All dimensions are in mm
5. Copper Strip – 25*6 mm or higher
6. Exothermic Welding

**Maintenance free earthing as per NBC-2016
(copper plate electrode with exothermic welding)**

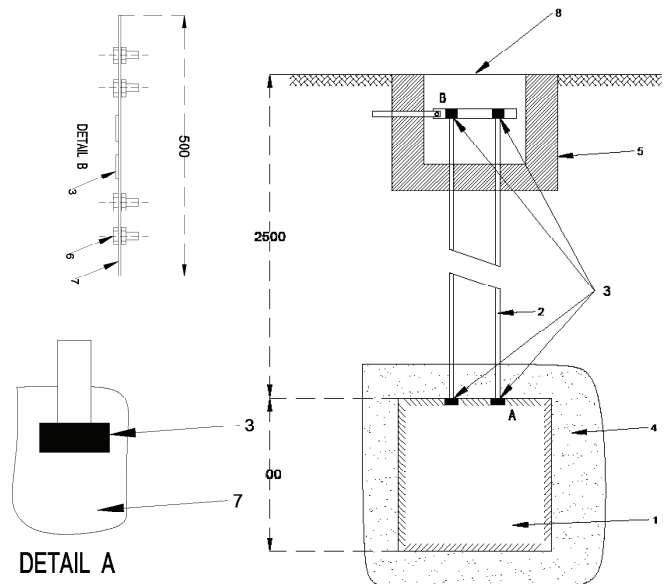

1. 600 x 600 x 1.5 mm copper plate
2. 30 x 6 mm copper strip
3. Exothermic welding
4. Earth enhancement material tested as per IEC 62561-7
5. Inspection Chamber

Maintenance free Earth Electrode (Vertical Rods)

CBR earthing rods are made of high tensile strength low carbon solid steel rod, molecularly bonded with 99.9% pure electrolytic grade copper. The rods are tested as per IEC 62561 for its mechanical and corrosion resistance behavior. In addition all 8 feet and 10 feet rods are UL listed.

These highly corrosion resistant rods can be used in Industrial, commercial and Residential applications to make maintenance free earthing system. These Copper bonded ground Rods are available in various sizes with 250 micron copper coating. The rods offer tensile strength above 600 N/mm². Compared to solid copper rods, CAPE CBE rods are much more stronger with a corrosion resistance almost equal to copper.

Test Confirmations -

- Tensile Strength: higher than 600 N/mm²
- Accelerated corrosion resistance test
- Salt mist test as per IEC 60068-2-52:1996.
- Humid sulphurous atmosphere test as per ISO 6988:1985 with Ammonia atmosphere test as per ISO 6957:1988

Available in both threaded and un threaded type

Rod dia in mm	Short Circuit Capacity		Application (for panel with nominal current rating)
	I _{pk}	I _{rms}	
14.2	31	14	upto 250A/LPS
17.2	45	18	250A - 400A
20	76	30	400A - 630A

All 8 feet and 10 feet rods



Model	Dimension			Article No
	D in mm	L in ft	L in mtr	
CBR 1410 *	14.2	10	3000	300 010
CBR 1406	14.2	6	2000	300 030
CBR 1710*	17.2	10	3000	300 060
CBR 1706	17.2	6	2000	300 080
CBR 2010	20	10	3000	300 110
CBR 2510	25	10	3000	300 150

Self Coupled Rods (Deep Driven Rods)

Model	Dimension		Article no
	D in mm	L in mm	
CBR 2003	20	1000	300 180
CBR 2503	25	1000	300 190

Maintenance free Earth Electrode (Plates)

Copper Plate Electrodes with connecting Wires are conforming to NBC-2016, UL as well as several national / international standards. These maintenance free plate electrodes offers long life. Electrode as well as conductors are made of high conductivity, non corrosive copper, exothermically welded to copper conductor in order to offer maximum life. The 2 meter long, 2 runs of connecting wires ensure deep burying of the plates in soil. Plate Electrodes of other sizes are available on request.

1. 600 * 600 * 1.5 mm copper plate
2. Exothermic Welding
3. Earth Enhancement Material
4. Earth Chamber
5. BUS BAR
6. 70 Sq.mm Multi stranded copper wire

Model	Plate Size (mm)	Wire Size in Sq.mm	Article no
CPE 600	600 x 600 x 1.5	70 (2 runs 2 meters each)	300 740

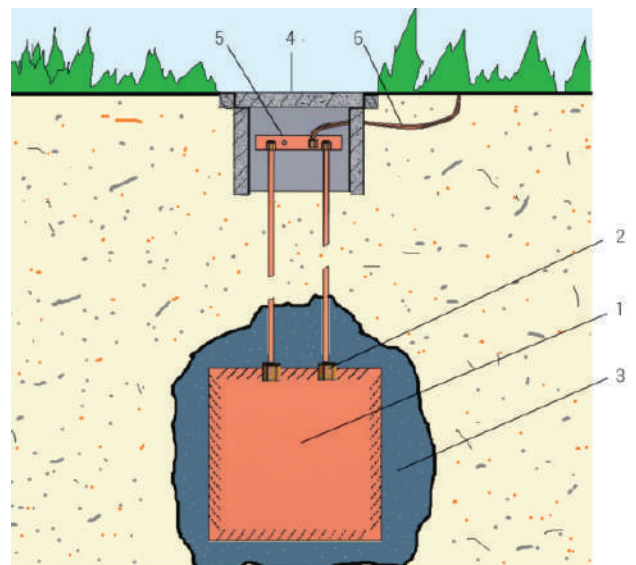

PRO-CEM Earth Enhancing compounds

PRO CEM is a Protective and conductive concrete based earth conductivity improvement compound, which hardens and become permanent conductive layer after installation. The chemicals used offers non corrosive behavior and is tested in accordance with IEC 62561.

- PRO-CEM is a concentration of minerals that improves earthing effectiveness, especially in areas of poor conductivity (rocky ground areas of moisture variation, sandy soils etc)
- PRO-CEM improves the contact area between earth electrode and soil
- PRO-CEM Protects earth electrode from corrosion,
- PRO-CEM is Permanent and NO Maintenance
- PRO-CEM can be used directly by mixing with the soil in 'dry' / 'slurry' form.
- PRO-CEM does not need watering as well as maintenance free for years.
- PRO-CEM is stable at 10 ° C to + 60 ° C.
- PRO-CEM is environmental friendly, not explosive, not harmful to eyes, skin etc.
- PRO-CEM is non corrosive
- PRO-CEM is acceptable in all types of earthing.

Model	Weight in kg	Packing	Article No)
PRO CEM 10..0	10	Bag	300 780
PROCEM 12.5	12.5	Bag	300 790



Exothermic Welding

Exothermic welding is a process which utilize high temperature of reaction between copper oxide and aluminium. The reaction happens in a graphite mould crucible, into which the pieces to be welded have been inserted. The molten metal from the exothermic reaction flows over the piece causing them to melt and fuse into a solid homogeneous mass. The WELD connection is a perfect molecular weld and not just a mechanical contact. Exothermic welding can be done between Copper to copper, Steel to copper and steel to steel.

Exothermic welding is tested as per IEEE837 and IEC 62561

- Mechanical Test (Electro Magnetic Force Test) to determine if the strength of connection due to electromagnetic forces during a fault.
- Current-temperature cycling test to ensure the performance criteria of connections subjected to temperature changes caused by fluctuating currents.
- Freeze-thaw test to ensure the resistance of the connections subjected to repeated cycles of freezing and thawing in water.
- Corrosion tests to evaluate the corrosion resistance of connections.
- Fault-current test to determine connection passing the previous tests will withstand fault-current surges.

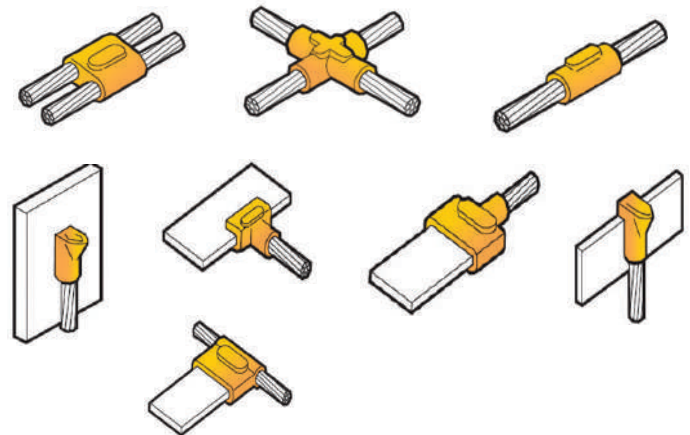

CAPE electric pvt ltd

A-41B, SIPCOT, Oragadam.
Kancheepuram District Tamilnadu
Pin: 602105; Phone No: 044 71018100
email: sales@capeindia.net;
Web: www.capeindia.net

CAPE
ELECTRIC